

# HUNTER WALL OUTDOOR

## DESIGN SPECIFICATIONS

<b>DIMENSIONS (mm)</b>	H 230 x D 225 - SHADE Ø 170
<b>WEIGHT (kg)</b>	1,1
<b>MATERIALS</b>	THE LAMP IS MADE FROM CLEAR LAQCUERD COPPER.
<b>CORD (mm)</b>	NO
<b>ENVIRONMENT</b>	INDOOR
<b>DESIGN BY</b>	NICLAS HOFLIN
<b>DESIGN YEAR</b>	2015

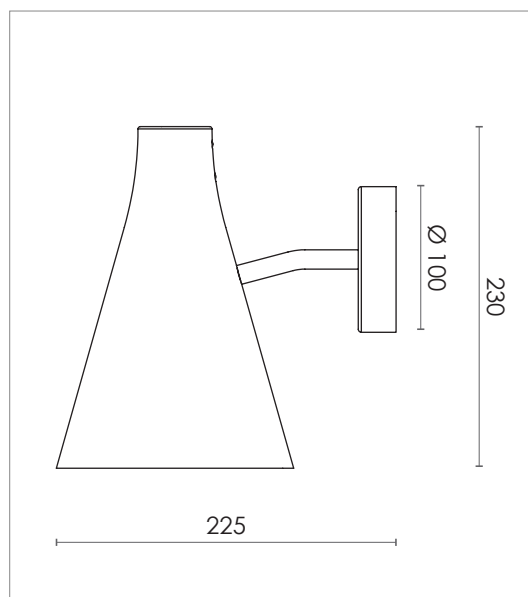

## ELECTRICAL SPECIFICATIONS

<b>SWITCH</b>	NO
<b>BULB HOLDER</b>	E27
<b>LIGHT SOURCE</b>	INCLUDED 7 W LED - 2700 K
<b>DIMMABLE</b>	YES
<b>MAX (W)</b>	10 W LED
<b>VOLTAGE</b>	230 / 240
<b>CLASS</b>	1
<b>IP</b>	44

## COLOURS



COPPER

ART.NO. 800215035